



HELICARRIER HEADQUARTERS

WARNING:
CHOKING HAZARD—Small parts.
Not for children under 3 years.

AGES 4+
19463

INCLUDES:

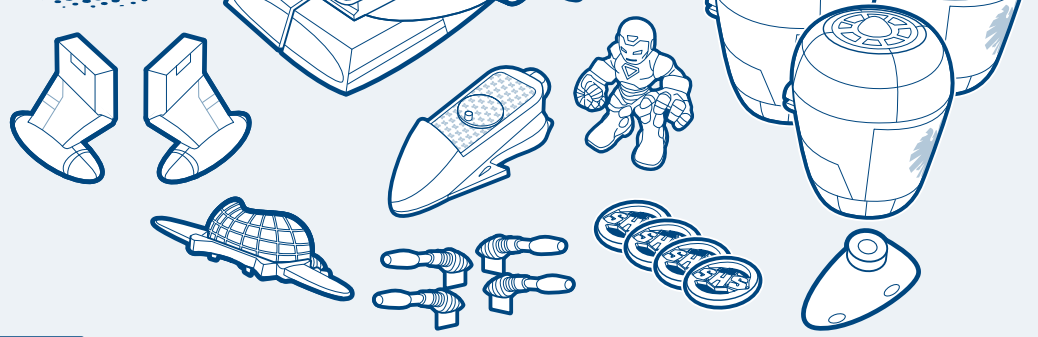

x3 BATTERIES REQUIRED
1.5V AAA or R03 size
NOT INCLUDED
Alkaline batteries recommended. Phillips/cross head screwdriver (not included) needed to insert batteries.

ASSEMBLY:

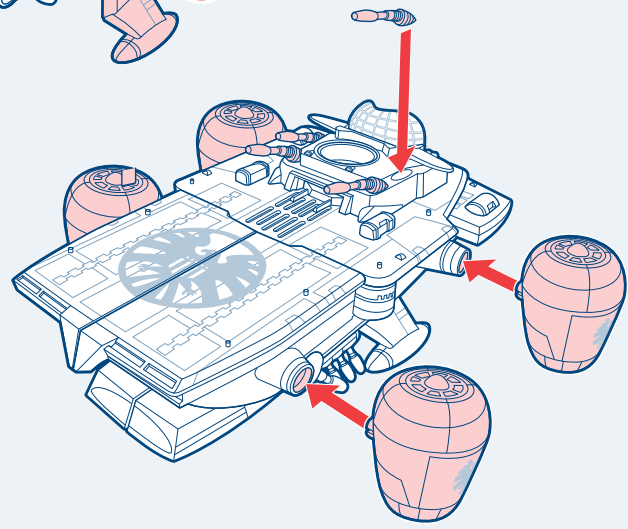
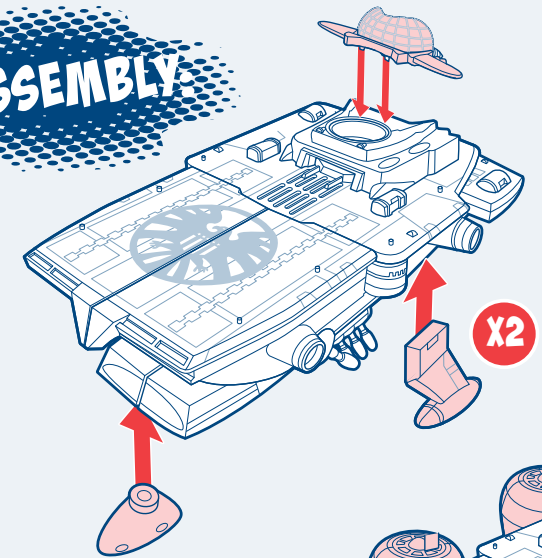

PLAY:

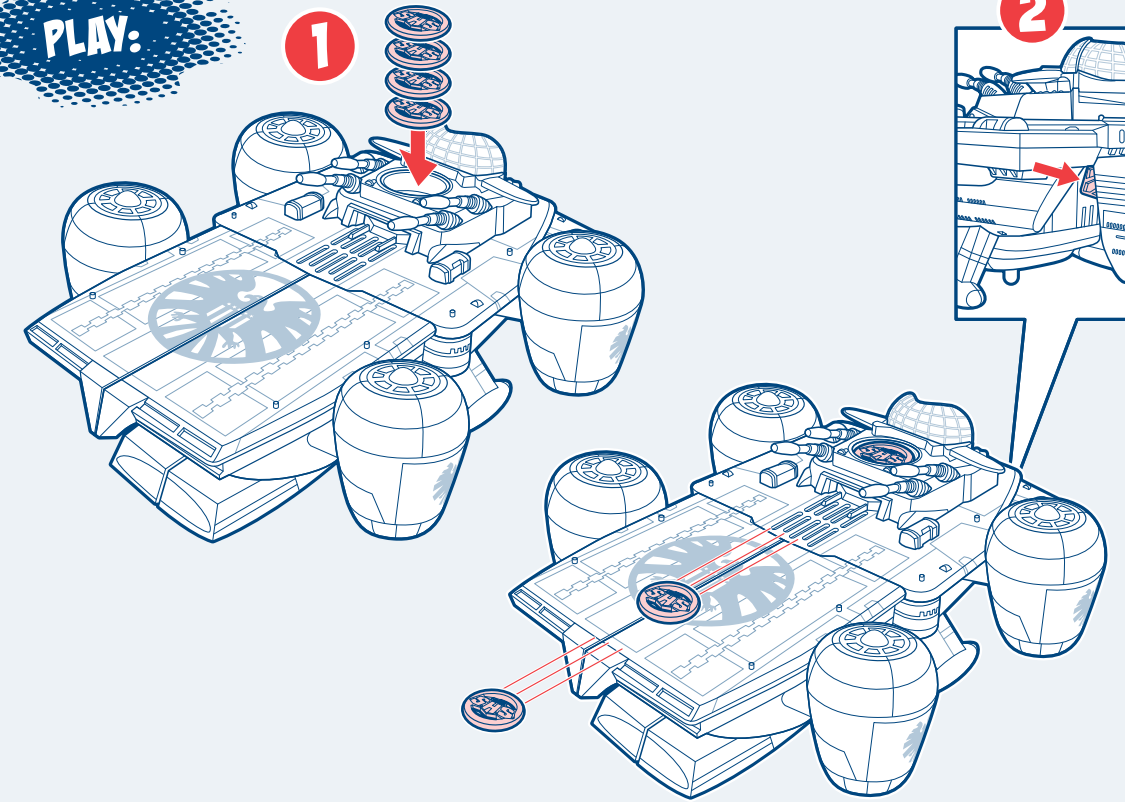

Activates sounds.
Press and hold
to hear the
SUPER HERO SQUAD™
theme song!

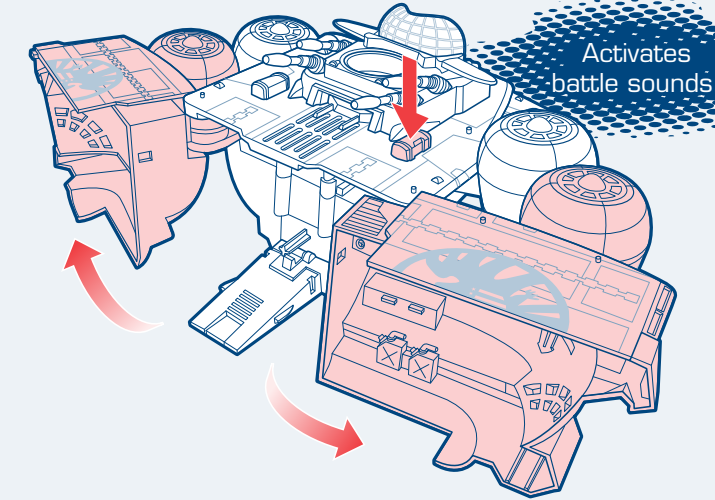

Activates
battle sounds

PEEL AND APPLY LABELS:

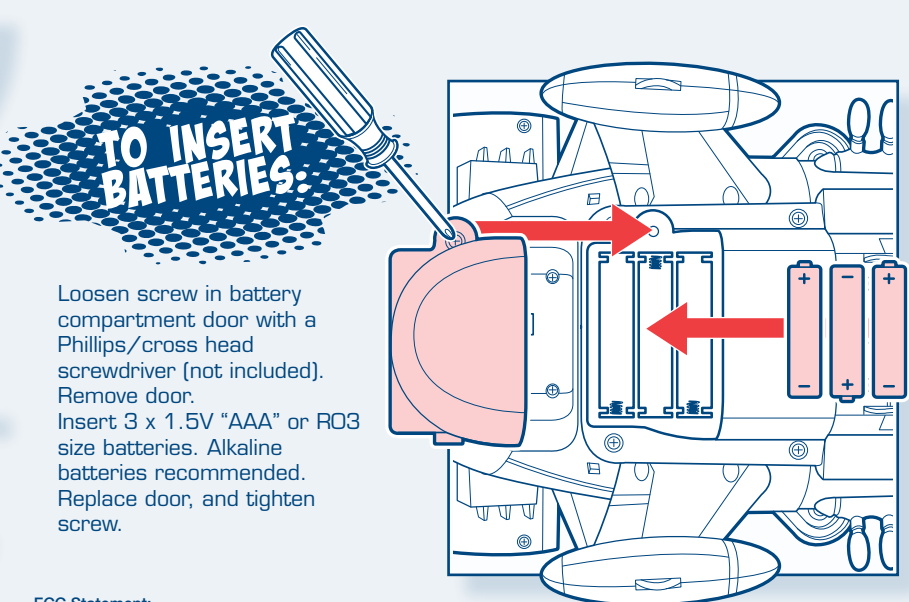
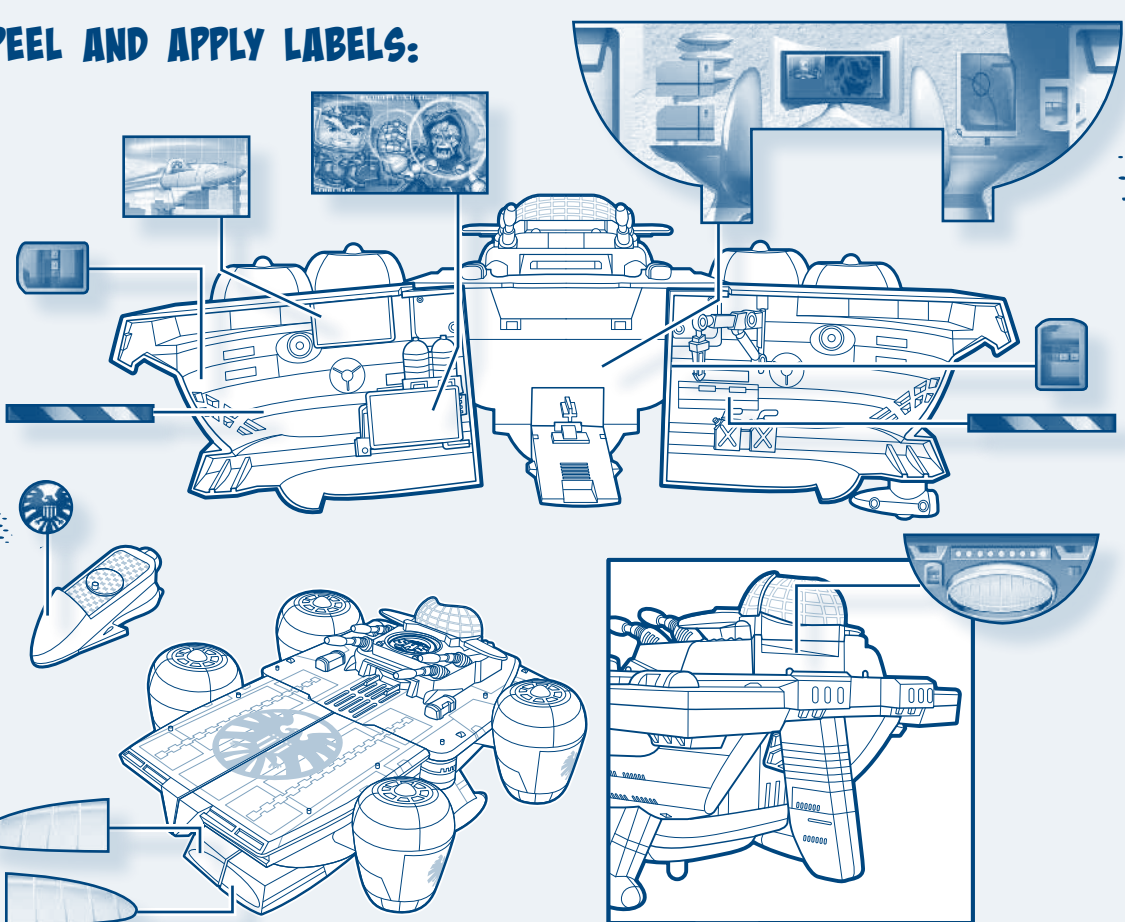
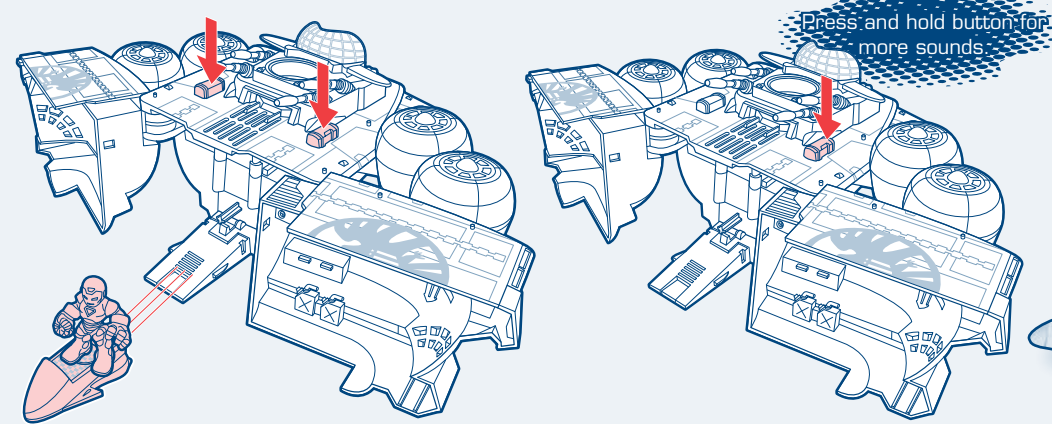
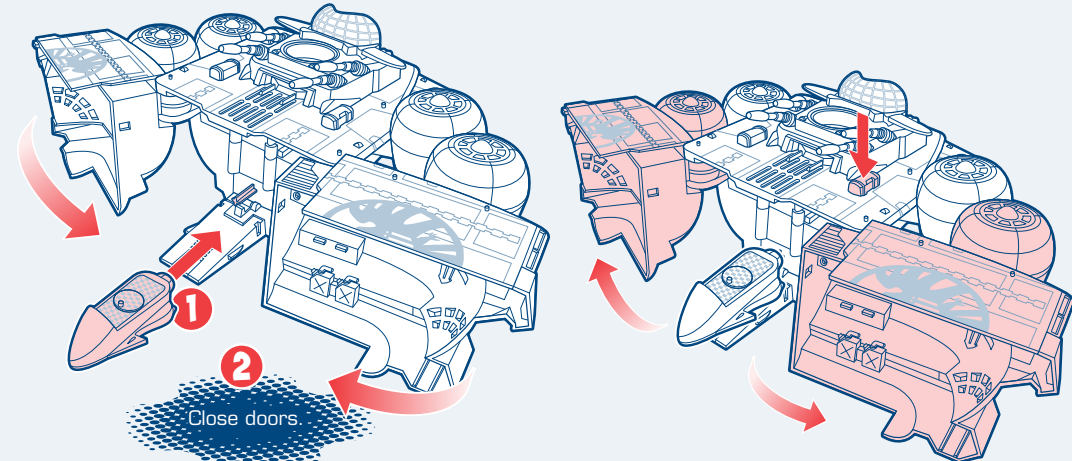

FCC Statement:
 This device complies with part 15 of the FCC Rules. Operation is subject to the following two conditions: (1) This device may not cause harmful interference, and (2) this device must accept any interference received, including interference that may cause undesired operation.
 This equipment has been tested and found to comply with the limits for a Class B digital device, pursuant to part 15 of the FCC Rules. These limits are designed to provide reasonable protection against harmful interference in a residential installation. This equipment generates, uses and can radiate radio frequency energy, and, if not installed and used in accordance with the instructions, may cause harmful interference to radio communications. However, there is no guarantee that interference will not occur in a particular installation. If this equipment does cause harmful interference to radio or television reception, which can be determined by turning the equipment off and on, the user is encouraged to try to correct the interference by one or more of the following measures:

- Reorient or relocate the receiving antenna.
- Increase the separation between the equipment and receiver.
- Consult the dealer or an experienced radio/TV technician for help.

CAUTION: Changes or modifications to this unit not expressly approved by the party responsible for compliance could void the user's authority to operate the equipment.

IMPORTANT: BATTERY INFORMATION

⚠ CAUTION:

1. As with all small batteries, the batteries used with this toy should be kept away from small children who still put things in their mouths. If they are swallowed, promptly see a doctor and have the doctor phone (202) 625-3333 collect. If you reside outside the United States, have the doctor call your local poison control center.
2. Always follow the instructions carefully. Use only batteries specified and be sure to insert them correctly by matching the + and - polarity markings.
3. Do not mix old batteries and new batteries or standard (carbon-zinc) with alkaline batteries.
4. Remove exhausted or dead batteries from the product.
5. Remove batteries if product is not to be played with for a long time.
6. Do not short-circuit the supply terminals.
7. Should this product cause, or be affected by, local electrical interference, move it away from other electrical equipment. Reset (switching off and back on again or removing and re-inserting batteries) if necessary.
8. **RECHARGEABLE BATTERIES:** Do not mix these with any other types of batteries. Always remove from the product before recharging. Recharge batteries under adult supervision. **DO NOT RECHARGE OTHER TYPES OF BATTERIES.**

 **NOTE TO UK CONSUMERS:** This product and its batteries must be disposed of separately at your local waste recycling centre. Do not dispose of in your household waste bin.



MARVEL, Super Hero Squad, all related characters and the distinctive likenesses thereof are trademarks of Marvel Entertainment, Inc. and its subsidiaries, and are used with permission. Copyright © 2009 Marvel Entertainment, Inc. and its subsidiaries. Licensed by Marvel Characters B.V. www.marvel.com All rights reserved.
 Super Hero(es) is a co-owned registered trademark.
 ® and/or TM & © 2009 Hasbro. All Rights Reserved.
 TM & © denote U.S. Trademarks.

PN 703466001



Not suitable for children under 3 years because of small parts — choking hazard.